

HWTF 型 高能液体钽固定电容器

★ 特征与用途 FEATURES AND APPLICATIONS

- ◆ 全钽外壳、气密封、圆柱形、同向引出、有极性，带固定安装螺杆。
- ◆ 产品是钽电解电容器和电化学电容器组成的混合电容器，体积小、单位体积能量密度大。
- ◆ 电性能优良稳定、可靠性高、寿命长、单位体积内能量密度大。
- ◆ 在能量转换电路、功率脉冲电路中可以作为电池使用，为电路提供储能、断电延时功能。



★ 主要技术性能 MAIN TECHNICAL PERFORMANCE

- ◆ 温度范围： $-55^{\circ}\text{C} \sim 125^{\circ}\text{C}$ ($>85^{\circ}\text{C}$ 时施加降额电压使用)；
- ◆ 额定电压、降额电压、标称电容量：见规格特性表；
- ◆ 电容器允许偏差： $\pm 10\%$ (K档)、 $\pm 20\%$ (M档)；
- ◆ 电容量变化、漏电流、损耗角正切、等效串联电阻和阻抗：见规格特性表规定；
- ◆ 外形尺寸、外壳代号及引出方式：见图1和表1规定；

★ 外观尺寸 SHAPE AND DIMENSIONS

HWTF - 3612 - 50V - 10000 μ F - K - 100 只

① ② ③ ④ ⑤ ⑥

- ① HWTF：高能液体钽固定电容器
- ② 尺寸代码
- ③ 50V、产品额定电压
- ④ 10000 μ F：电容量10000 μ F
- ⑤ K：电容公差 $\pm 10\%$
- ⑥ 100只：订货数量

★ 外观尺寸 SHAPE AND DIMENSIONS



表 1 电容器的外形尺寸及外壳代号

单位: mm

外壳代号	外形尺寸				
	D	H	L2	L1	D1
1208	12 ± 0.12	7.92 ± 0.3	5.84 ± 0.76	≥7	4.00 ± 0.38
1210		9.98 ± 0.3			
1212		11.98 ± 0.3			
1608	15.96 ± 0.12	7.92 ± 0.3	5.84 ± 0.76	≥7	5.08 ± 0.38
1610		9.98 ± 0.3			
1612		11.98 ± 0.3			
1616		15.44 ± 0.3			
2208	22 ± 0.12	7.92 ± 0.3	5.84 ± 0.76	≥7	7.50 ± 0.38
2210		9.98 ± 0.3			
2212		11.98 ± 0.3			
2216		15.44 ± 0.3			
2218		17.98 ± 0.3			
2220		19.68 ± 0.3			
3608	35.56 ± 0.12	7.92 ± 0.3	5.84 ± 0.76	≥7	10.16 ± 0.38
3610		9.98 ± 0.3			
3612		11.98 ± 0.3			
3616		15.44 ± 0.3			
3618		17.98 ± 0.3			
3620		19.68 ± 0.3			
3624		23.98 ± 0.3			

★ 规格特性

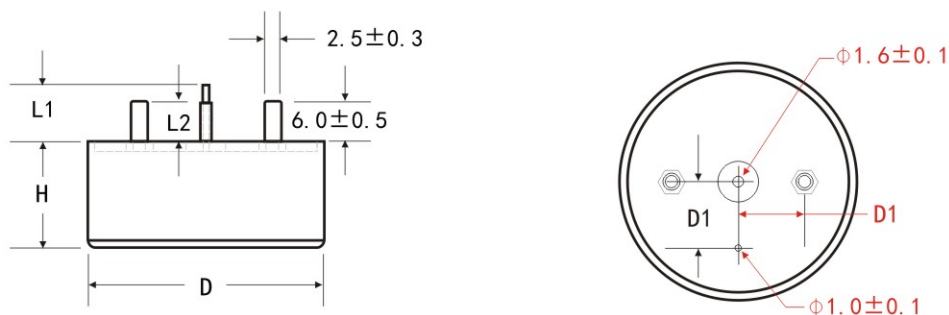
SPECIFICATIONS

额定电压 (U_R) V	标称容 量(C_R) μF	最大值									尺寸代码
		损耗 (100Hz) %	ESR (1kHz) Ω	漏电流 μA			阻抗 (100Hz, -55 $^{\circ}C$) Ω	电容量变化(100Hz)%			
				25 $^{\circ}C$	85 $^{\circ}C$	125 $^{\circ}C$		-55 $^{\circ}C$	85 $^{\circ}C$	125 $^{\circ}C$	
10	4000	120	0.36	32	256	320	10	-80	85	100	1208
10	8000	120	0.18	64	512	640	5	-80	85	100	1212
10	8000	120	0.3	64	512	640	8	-80	85	100	1608
10	15000	120	0.2	120	960	1200	5	-80	85	100	1612
10	22000	120	0.1	180	1440	1800	4	-80	85	100	1616
10	15000	130	0.12	120	960	1200	4.8	-80	85	100	2208
10	30000	130	0.06	200	1600	2000	2.4	-80	85	100	2212
10	45000	130	0.04	200	1600	2000	1.6	-80	85	100	2216
10	60000	130	0.03	300	2400	3000	1.2	-80	85	100	2220
10	50000	180	0.05	200	1600	2000	2	-80	80	100	3608
10	100000	180	0.03	300	2400	3000	1	-80	80	100	3612
10	150000	180	0.025	300	2400	3000	1	-80	80	100	3616
10	200000	190	0.025	500	4000	5000	1	-80	80	100	3620
10	250000	190	0.025	600	4800	6000	1	-80	80	100	3624
16	2000	100	0.36	25	200	250	10	-80	85	100	1208
16	4000	100	0.18	50	400	500	5	-80	85	100	1212
16	5000	100	0.3	64	512	640	8	-80	85	100	1608
16	9000	100	0.2	110	880	1100	5	-80	85	100	1612
16	13500	100	0.1	170	1360	1700	4	-80	85	100	1616
16	10000	110	0.12	120	960	1200	4.8	-80	85	100	2208
16	20000	110	0.06	190	1520	1900	2.4	-80	85	100	2212
16	30000	110	0.04	190	1520	1900	1.6	-80	85	100	2216
16	40000	110	0.03	200	1600	2000	1.2	-80	85	100	2220
16	30000	160	0.05	190	1520	1900	2	-80	80	100	3608
16	60000	165	0.03	300	2400	3000	1	-80	80	100	3612
16	90000	165	0.025	300	2400	3000	1	-80	80	100	3616
16	120000	170	0.025	500	4000	5000	1	-80	80	100	3620
16	150000	170	0.025	600	4800	6000	1	-80	80	100	3624
25	1500	80	0.36	30	240	300	10	-75	80	100	1208
25	3000	80	0.18	60	480	600	5	-75	80	100	1212
25	3000	80	0.3	60	480	600	8	-75	80	100	1608
25	6000	80	0.2	120	960	1200	5	-75	80	100	1612
25	9000	80	0.1	180	1440	1800	4	-75	80	100	1616
25	6000	85	0.12	120	960	1200	4.8	-75	80	100	2208
25	12000	85	0.06	240	1920	2400	2.4	-75	80	100	2212
25	18000	85	0.04	200	1600	2000	1.6	-75	80	100	2216



★ 规格特性

SPECIFICATIONS

额定电压 (U_R) V	标称容 量(C_R) μF	最大值									尺寸代码
		损耗 (100Hz) %	ESR (1kHz) Ω	漏电流 μA			阻抗 (100Hz, -55°C) Ω	电容量变化(100Hz)%			
				25°C	85°C	125°C		-55°C	85°C	125°C	
25	24000	85	0.03	480	3840	4800	1.2	-75	80	100	2220
25	18000	120	0.06	150	1200	1500	2	-80	75	100	3608
25	36000	130	0.045	300	2400	3000	1	-80	75	100	3612
25	54000	130	0.035	350	2800	3500	1	-80	75	100	3616
25	70000	140	0.025	400	3200	4000	1	-80	75	100	3620
25	90000	140	0.025	500	4000	5000	1	-80	75	100	3624
35	1000	50	0.36	28	224	280	12	-75	80	100	1208
35	2000	50	0.18	56	448	560	6	-75	80	100	1212
35	2500	50	0.3	70	560	700	10	-75	80	100	1608
35	4600	50	0.2	130	1040	1300	5	-75	80	100	1612
35	7000	50	0.1	200	1600	2000	4	-75	80	100	1616
35	5200	55	0.12	150	1200	1500	4.8	-75	80	100	2208
35	10400	55	0.06	290	2320	2900	2.4	-75	80	100	2212
35	15600	55	0.04	200	1600	2000	1.6	-75	80	100	2216
35	20800	55	0.03	300	2400	3000	1.2	-75	80	100	2220
35	12000	90	0.1	150	1200	1500	2	-80	75	100	3608
35	24000	95	0.05	300	2400	3000	1	-80	75	100	3612
35	36000	95	0.035	300	2400	3000	1	-80	75	100	3616
35	50000	100	0.025	400	3200	4000	1	-80	75	100	3620
35	60000	100	0.025	500	4000	5000	1	-80	75	100	3624
50	700	40	0.36	28	224	280	13	-75	70	100	1208
50	1400	40	0.18	56	448	560	7	-75	70	100	1212
50	1400	40	0.3	56	448	560	11	-75	70	100	1608
50	2800	40	0.2	110	880	1100	5	-75	70	100	1612
50	4200	40	0.1	170	1360	1700	5	-75	70	100	1616
50	3000	45	0.12	120	960	1200	6	-75	70	100	2208
50	6000	45	0.06	240	1920	2400	3	-75	70	100	2212
50	9000	45	0.04	360	2880	3600	2	-75	70	100	2216
50	12000	45	0.03	480	3840	4800	1.5	-75	70	100	2220
50	8000	65	0.08	170	1360	1700	5	-75	70	100	3608
50	16000	70	0.045	300	2400	3000	2.5	-75	70	100	3612
50	24000	70	0.035	400	3200	4000	1.5	-75	70	100	3616
50	32000	75	0.025	550	4400	5500	1.5	-75	70	100	3620
50	40000	75	0.025	600	4800	6000	1.5	-75	70	100	3624
63	500	30	0.42	25	200	250	17	-70	70	100	1208
63	1000	30	0.21	50	400	500	8	-70	70	100	1212
63	600	30	0.35	30	240	300	14	-70	70	100	1608
63	1800	30	0.15	90	720	900	5	-70	70	100	1612

★ 规格特性

SPECIFICATIONS

额定电压 (U_R) V	标称容 量(C_R) μF	最大值									尺寸代码
		损耗 (100Hz) %	ESR (1kHz) Ω	漏电流 μA			阻抗 (100Hz, -55°C) Ω	电容量变化(100Hz)%			
				25°C	85°C	125°C		-55°C	85°C	125°C	
63	2200	40	0.25	110	880	1100	8	-70	70	100	1616
63	1300	35	0.18	65	520	650	6	-70	70	100	2208
63	2600	35	0.09	130	1040	1300	3	-70	70	100	2212
63	3900	35	0.06	190	1520	1900	2	-70	70	100	2216
63	5200	35	0.05	260	2080	2600	1.5	-70	70	100	2220
63	4000	45	0.1	170	1360	1700	5	-70	70	100	3608
63	8000	50	0.055	350	2800	3500	2.5	-70	70	100	3612
63	12000	50	0.035	400	3200	4000	1.5	-70	70	100	3616
63	16000	55	0.035	500	4000	5000	1.5	-70	70	100	3620
63	20000	55	0.035	600	4800	6000	1.5	-70	70	100	3624
80	400	25	0.42	25	200	250	17	-65	70	75	1208
80	800	25	0.21	52	416	520	8	-65	70	75	1212
80	500	25	0.35	32	256	320	14	-65	70	75	1608
80	1000	25	0.25	64	512	640	8	-65	70	75	1612
80	1500	25	0.15	96	768	960	5	-65	70	75	1616
80	1100	30	0.18	70	560	700	6	-65	70	70	2208
80	2200	30	0.09	140	1120	1400	3	-65	70	70	2212
80	3300	30	0.06	210	1680	2100	2	-65	70	70	2216
80	4400	30	0.05	280	2240	2800	1.5	-65	70	70	2220
80	2800	40	0.15	200	1600	2000	5	-65	50	65	3608
80	5600	40	0.08	360	2880	3600	2.5	-65	50	65	3612
80	8200	40	0.06	500	4000	5000	2	-65	50	65	3616
80	11000	45	0.035	500	4000	5000	2	-65	50	65	3620
80	14000	45	0.035	900	7200	9000	2	-65	50	65	3624
100	300	25	0.48	24	192	240	24	-55	65	70	1208
100	600	25	0.24	50	400	500	12	-55	65	70	1212
100	180	25	0.4	15	120	150	20	-55	65	70	1608
100	360	25	0.35	30	240	300	12	-55	65	70	1612
100	540	25	0.3	45	360	450	5	-55	65	70	1616
100	400	25	0.36	32	256	320	6	-55	65	70	2208
100	800	25	0.18	65	520	650	3	-55	65	70	2212
100	1200	25	0.12	100	800	1000	2	-55	65	70	2216
100	1600	25	0.09	200	1600	2000	1.5	-55	65	70	2220
100	1200	35	0.13	100	800	1000	8	-50	55	60	3608
100	2400	35	0.1	300	2400	3000	4	-50	55	60	3612
100	3600	35	0.075	400	3200	4000	2	-50	55	60	3616
100	4800	40	0.05	500	4000	5000	2	-50	55	60	3620
100	6000	40	0.05	500	4000	5000	2	-50	55	60	3624

★ 规格特性

SPECIFICATIONS

额定电压 (U_R) V	标称容 量(C_R) μF	最大值									尺寸代码
		损耗 (100Hz) %	ESR (1kHz) Ω	漏电流 μA			阻抗 (100Hz, -55°C) Ω	电容量变化(100Hz)%			
				25°C	85°C	125°C		-55°C	85°C	125°C	
110	2800	35	0.15	250	2000	2500	2.5	-35	50	60	3616
125	100	20	0.5	10	80	100	20	-30	45	50	1608
125	200	20	0.4	20	160	200	12	-30	45	50	1612
125	470	20	0.4	47	376	470	5	-30	45	50	1616
125	300	25	0.48	30	240	300	6	-30	45	50	2208
125	600	25	0.24	47	376	470	3	-30	45	50	2212
125	900	25	0.16	90	720	900	2	-30	45	50	2216
125	1200	25	0.12	200	1600	2000	1.5	-30	45	50	2220
125	1100	35	0.2	200	1600	2000	8	-40	35	40	3608
125	2200	35	0.15	400	3200	4000	2.5	-40	35	40	3612
125	3300	30	0.075	500	4000	5000	2.5	-40	35	40	3618
125	4500	35	0.05	500	4000	5000	2.5	-40	35	40	3620
125	5500	35	0.05	550	4400	5500	2.5	-40	35	40	3624

注：要了解以上规格以外的产品，请联系顺络迅达电子。